

# 1-082SL Quarter-Turn Pr30 L18 SNAP-LINE

Tool-less installation, Tool or hand operable



## Product Notes:

- RH and LH application
- Pre-assembled Quarter-Turn can be installed in cutout 30x30mm
- Cutouts can have indentations to ensure correct positional installation,
- Low profile
- Screw-on installation - see Product System 1-100 and 1-100.01
- Other tool-less installation - see Product System 1-083SL
- Stainless steel - see Product System 7-080 and 7-080.01
- **NOTE: H-dimension  $\geq 14\text{mm}$  (0.551)**

## Material:

- **Housing:** Zinc Die, Black
- **Wings:** Sintered Steel
- **Clip:** Spring Steel

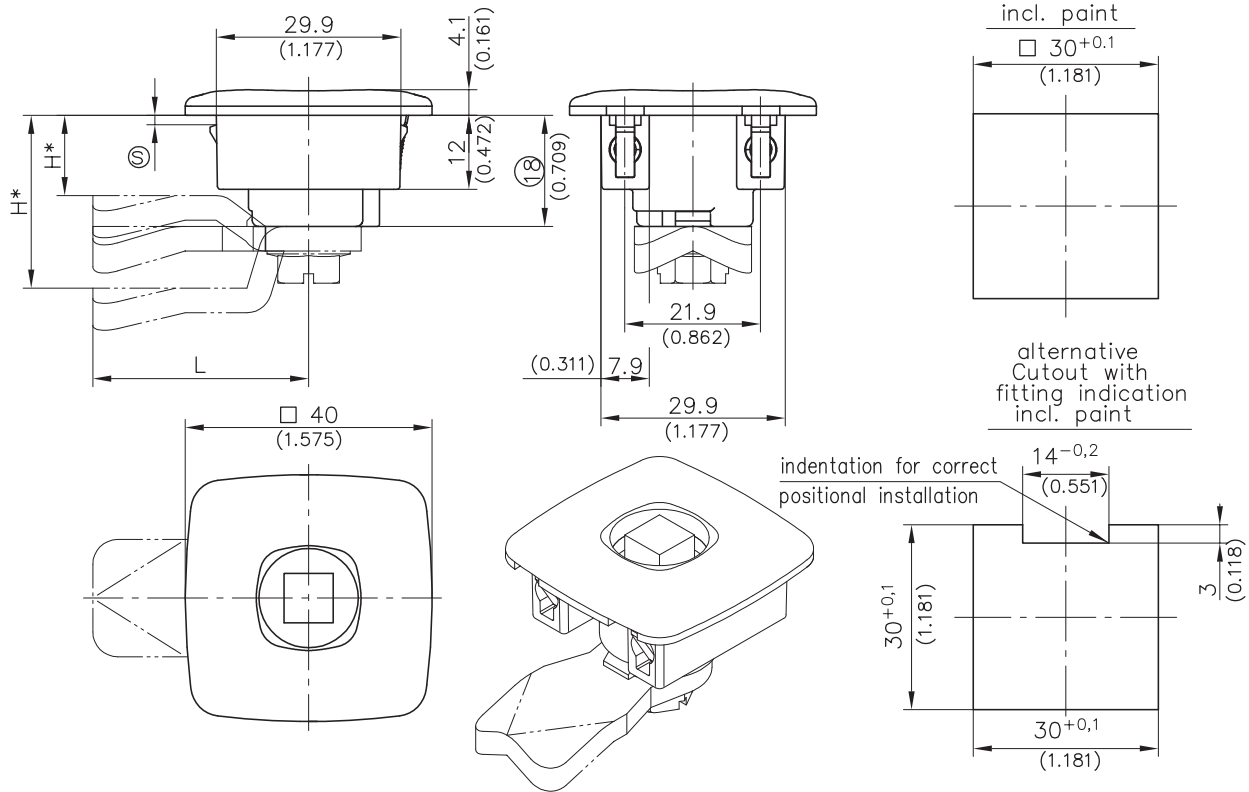

	Clamping Range $\text{\textcircled{S}}$	Heavy Applications (4 Wings)	Light Applications (2 Wings)	See Page
a) Housing	0.8 - 1.5	406-9001.00-00015	406-9002.00-00015	
	1.3 - 2.0	406-9001.00-00020	406-9002.00-00020	
	1.5 - 2.2	406-9001.00-00022	406-9002.00-00022	
<b>Other <math>\text{\textcircled{S}}</math> - dimension on request</b>				
b) Inserts				01.42, 01.98, 01.99, 01.24
c) Cams				01.42, 01.101, 01.102
3-point cams				01.101
d) Grounding clip		200-1105.93-00000	200-1105.93-00000	
<b>Optional:</b>				
<b>Water and dust tight according to IP65 by:</b>				
e) O-ring for insert		200-1001.00-00000	200-1001.00-00000	
f) O-ring 36x2mm		839-3770.00-03620	839-3770.00-03620	
g) Tool for uninstallation		292-0306.80-02530	292-0306.80-02530	